



Cat[®] 908

COMPACT WHEEL LOADER

FEATURES:

CONFIGURED FOR SUCCESS

- Cat[®] wheel loaders set the standard for productivity, fuel efficiency and operator comfort. The Cat 908 Compact Wheel Loader has a high torque C2.8 engine that works in conjunction with an intelligent hystat power train to deliver exceptional fuel efficiency. Dependent on regional requirements our engines meet EU Stage IIIA (EPA Tier 3) or EU Stage V (EPA Tier 4 Final) with a clean emission module designed to manage itself so you can concentrate on the task at hand.

ENJOY ALL DAY COMFORT

- All new cab is spacious, quiet and comfortable with all around 360° visibility to keep you productive throughout the day. Seat-mounted controls feature a multifunction joystick for lift and tilt functions with an integrated thumb operated speed range, forward/neutral/reverse (FNR) switch, trigger operated differential lock and constant flow. Optional fourth function joystick also available.
- Digital display with soft touch buttons for customized settings to easily control linkage and drive train to further enhance operator comfort and safety.

EFFICIENTLY POWERFUL

- Cat C2.8 engine provides a cleaner, quieter operation while delivering superior performance and durability through a high torque, low speed design. Caterpillar's exclusive Intelligent Power Management system monitors operator input and available power to keep the machine working at peak efficiency.

- "Shift on the go" locking differentials and hydrostatic transmission provide smooth and powerful operation while increasing the efficiency of machine cycles. New Utility Mode via the display enables right pedal machine operation giving further improved operator controllability of attachment RPM versus machine ground speed over creep control and inching pedal.

WORK MADE EASY

- All-in-one joystick to keep eyes on the work while maximizing operation of hydro-mechanical attachments with a state of the art pressure compensated electro-hydraulic system. Optimized Z-bar linkage for great performance and versatility with buckets that now have the DNA of the larger Cat loaders, such as curved side plates and a flat torque tube for parallel reference to the cutting edge.

CUSTOMIZE YOUR EXPERIENCE

- Work as one with your machine by customizing the controls. Operator can adjust machine responsiveness with the push of a button based on the attachment or application. Once customized, settings can be locked with "simplified mode" to ensure the machine is consistent and intuitive for every user.
- Machine security is enhanced with a standard keycode or optional Bluetooth[®] technology. Machines can be configured to meet your application specific needs: Agriculture, General Construction, Industrial and Waste, Landscaping or Snow Removal. Experience the new industry benchmark.

Specifications

Engine

Engine Model	Cat [®] C2.8*	
Maximum Engine Speed	2,550 rpm	
Maximum Gross Power		
Rated Engine Speed	2,400 rpm	
SAE J1995	55.7 kW	74.7 hp
ISO 14396	55.4 kW	74.3 hp
ISO 14396 (metric)	75.3 mhp	
Rated Net Power		
Rated Engine Speed	2,400 rpm	
SAE J1349	54.2 kW	72.7 hp
ISO 9249	53.8 kW	72.1 hp
ISO 9249 (metric)	73.1 mhp	
Maximum Gross Torque#		
SAE J1995	300 N-m	222 lb-ft
ISO 14396	300 N-m	221 lb-ft
Maximum Net Torque#		
SAE J1349	296 N-m	218 lb-ft
ISO 9249	295 N-m	217 lb-ft

Engine (continued)

Displacement	2.8 L	171 in ³
Bore	90 mm	3.54 in
Stroke	110 mm	4.33 in

- Net power ratings are tested at the reference conditions for the specified standard.
 - Net power advertised is the power available at the flywheel.
- *Two Cat C2.8 engine emission options are available:
- 1) Meets U.S. EPA Tier 4 Final, EU Stage V.
 - 2) Meets U.S. EPA Tier 3 and EU Stage IIIA. Tier 3 engine specs are 0.3 kW/0.4 hp more gross power (SAE J1995), 0.2 kW/0.3 hp on net power (SAE J1349) and 1 N-m/0.7 lb-ft higher on gross torque (SAE 1995).

#Maximum gross and net torque measured at 1,600 rpm.



908 Compact Wheel Loader

Specifications

Buckets

Bucket Capacities – General Purpose	0.80-1.35 m ³	1.0-1.7 yd ³
Bucket Capacities – Multi Purpose	0.75-1.1 m ³	1.0-1.4 yd ³
Bucket Capacities – Light Material	1.25-1.55 m ³	1.6-2.0 yd ³

- All capacities are applicable for each model. Bucket selection must be made with an understanding of the material density and application to ensure machine stability is maintained within the tipping loads stated per model and configuration.
- Bucket capacities stated include BOCE, in line with ISO 7546.

Service Refill Capabilities

Fuel Tank (including filter and lines)	90 L	24 gal
Cooling System	12 L	3.2 gal
Engine Crankcase	8.8 L	2.3 gal
Axles – Front Center Differential	8.8 L	2.3 gal
Axles – Rear Center Differential	8.8 L	2.3 gal
Hydraulic System (including tank)	70.5 L	18.6 gal
Hydraulic Tank	44.6 L	11.8 gal
Transmission	2.4 L	0.6 gal

- No Diesel Exhaust Fluid (DEF) fluid needed on this size engine.

Axles

Front	Fixed Locking Differential (standard)
Rear	Fixed Locking Differential (standard)

- Oscillation of ±11 degrees via hitch between front and rear frames.

Steering

Steering Articulation Angle (each direction)	39°	
Maximum Flow – Steering Pump	46.7 L/min	12.3 gal/min
Maximum Working Pressure – Steering Pump	23 000 kPa	3,336 psi
Steering Cycle Times – (full left to full right) – at High Idle	3.0 sec	
Number of Steering Wheel Turns – Full Left to Full Right or Full Right to Full Left	3.25 turns	4.00 turns

Transmission

Forward and Reverse:

Speed Range Creep#	10 km/h	6 mph
Speed Range 1*	10 km/h	6 mph
Speed Range 2** – High Speed	18 km/h	11 mph
Speed Range 2** – Standard	19 km/h	12 mph
Speed Range 3***	40 km/h	25 mph

#Factory default shown, can be adjusted to any speed up to 19 km/h (12 mph).

*Creep function not available in this gear or above.

**Max speed dependent on model and configuration (standard vs. high speed transmission).

***Reverse is 30 km/h (19 mph).

Tires

Standard Size	405/70 R20 SPT9*
Other Choices Include:	405/70 R20 Powerloads 400/70 R20 XMCL/Bibload 360/80 R20 TRI 2 40X14-20 TL, SM/TR

- Other tire choices are available. Contact your Cat dealer for details.
- In certain applications, the loader's productive capabilities may exceed the tire's tonnes-km/h (ton-mph) capabilities.
- Caterpillar recommends that you consult a tire supplier to evaluate all conditions before selecting a tire model.

*This tire has been used for all dimension, stability and performance data.

Cab

ROPS ISO 3471:2008
FOPS ISO 3449:2005 Level II

- Canopy and cab, Rollover Protective Structures (ROPS) are available worldwide. Canopy not available in EU.
- The declared dynamic operator sound pressure levels per ISO 6396:2008*, when properly installed and maintained, is 71 dB(A).
- The labelled sound power level for the CE marked configurations when measured according to the test procedure and conditions specified in 2000/14/EC is 101 dB(A). 99 dB(A) Low Sound – Option available.

*Measurements were conducted with the cab doors and windows closed.

Loader Hydraulic System

Main Relief – 1st Auxiliary (3rd slice)	23 500 kPa	3,408 psi
Standard Flow*	85 L/min	22.4 gal/min
High Flow*	120 L/min	31.7 gal/min
Main Relief – 2nd Auxiliary (4th slice)	23 500 kPa	3,408 psi
Flow	43 L/min	11.4 gal/min
Hydraulic Cycle Time		
Rack Back	2.5 seconds	
Lift	5.8 seconds	
Dump	1.8 seconds	
Float down	5.5 seconds	

*Adjustable from 20% to 100% of maximum flow through display.

908 Compact Wheel Loader

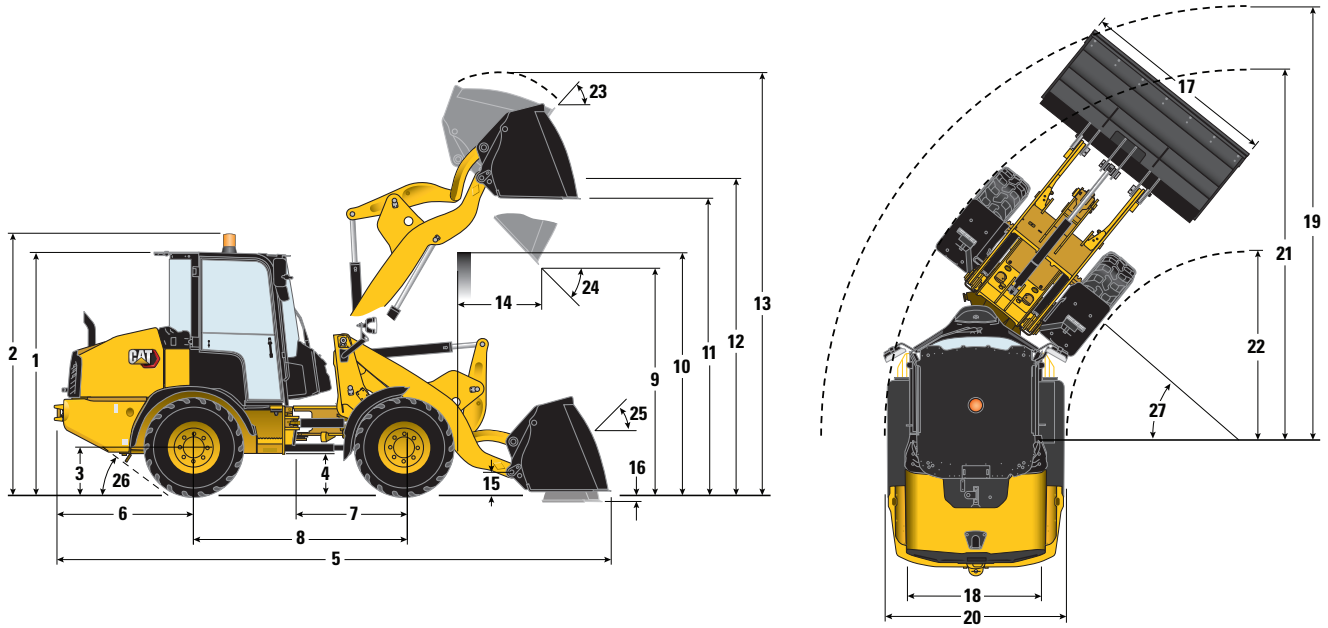

Dimensions

	908		908 High Lift		908				908 High Lift			
	Horizontal Pin Lock Coupler (HPL-V)#	Vertical Pin Coupler (SSL)	Horizontal Pin Lock Coupler (HPL-V)#	Vertical Pin Coupler (SSL)	Horizontal Pin Lock Coupler (HPL-V)#	Vertical Pin Coupler (SSL)	Horizontal Pin Lock Coupler (HPL-V)#	Vertical Pin Coupler (SSL)	Horizontal Pin Lock Coupler (HPL-V)#	Vertical Pin Coupler (SSL)	Horizontal Pin Lock Coupler (HPL-V)#	Vertical Pin Coupler (SSL)
	mm	ft/in	mm	ft/in	kg	lb	kg	lb	kg	lb	kg	lb
**1 Height: Ground to Cab	2670	8'9"	2670	8'9"	2670	8'9"	2670	8'9"	6632	14,617	6718	14,806
**2 Height: Ground to Beacon	2853	9'4"	2853	9'4"	2853	9'4"	2853	9'4"	4812	10,604	4347	9,581
**3 Height: Ground Axle Center	519	1'8"	519	1'8"	519	1'8"	519	1'8"	4113	9,064	3749	8,262
**4 Height: Ground Clearance	320	1'0"	320	1'0"	320	1'0"	320	1'0"	4060	8,947	3623	7,985
*5 Length: Overall	5549	18'2"	5707	18'8"	6163	20'2"	6319	20'8"	3446	7,595	3126	6,888
6 Length: Rear Axle to Bumper	1391	4'6"	1391	4'6"	1391	4'6"	1391	4'6"	6467	14,252	6530	14,391
7 Length: Hitch to Front Axle	1085	3'6"	1085	3'6"	1085	3'6"	1085	3'6"	6771	14,923	6834	15,062
8 Length: Wheel Base	2170	7'1"	2170	7'1"	2170	7'1"	2170	7'1"	3920	8,639	3649	8,043
*9 Clearance: Bucket at 45°	2615	8'6"	2502	8'2"	3294	10'9"	3131	10'3"	2638	5,813	2468	5,438
**10 Clearance: Load over Height	2957	9'8"	2957	9'8"	4238	14'1"	4238	14'1"	2152	4,743	1982	4,368
**11 Clearance: Level Bucket	3197	10'5"	3189	10'5"	3682	12'0"	3675	12'0"				
**12 Height: Bucket Pin	3404	11'1"	3404	11'1"	3889	12'9"	3889	12'9"				
**13 Height: Overall	4304	14'1"	4395	14'5"	4789	15'8"	4880	16'0"				
*14 Reach: Bucket at 45°	770	2'6"	872	2'10"	1042	3'5"	1098	3'7"				
15 Carry Height: Bucket Pin	353	1'1"	374	1'2"	508	1'8"	529	1'8"				
**16 Dig Depth	109	0'4.2"	117	0'4.5"	72	0'2"	80	0'3"				
17 Width: Bucket	2080	6'9"	2080	6'9"	2080	6'9"	2080	6'9"				
18 Width: Tread Center	1570	5'1"	1570	5'1"	1570	5'1"	1570	5'1"				
19 Turning Radius: Over Bucket	4570	14'11"	4613	15'1"	4869	15'11"	4912	16'1"				
20 Width: Over Tires	1990	6'6"	1990	6'6"	1990	6'6"	1990	6'6"				
21 Turning Radius: Outside of Tires	4087	13'4"	4087	13'4"	4087	13'4"	4087	13'4"				
22 Turning Radius: Inside of Tires	2033	6'8"	2033	6'8"	2033	6'8"	2033	6'8"				
23 Rack Angle at Full Lift	53°	49°	70°	66°								
24 Dump Angle at Full Lift	45°	45°	40°	33°								
25 Rack Angle at Carry	51°	53°	47°	41°								
26 Departure Angle	30°	30°	30°	30°								
27 Articulation Angle	39°	39°	39°	39°								

* Vary with bucket

** Vary with tire

^ HPL-V or SSL, 1.15 m³ (1.5 yd³) general purpose bucket.

^^ HPL-V or SSL, class II carriage, 1220 mm (4 ft) tines (500 mm [20 in] load center).

† Full compliance to ISO 14397-1 (2007) Sections 1 thru 6 (fork 500 mm [20 in] load center), which requires 2% verification between calculation and testing.

†† Full compliance to EN474-3 and SAE J1197.

HPL-A weight, tipping and rated loads are within 1% of the HPL-V.

Dimensions listed are for a machine configured with standard cab, heater, 20 km/h (12 mph), standard guarding, 80 kg (176 lb) operator, full fluids, SPT9 405/70 R18 tires and 1.15 m³ (1.5 yd³) general purpose bucket with bolt-on cutting edge or a class II fork carriage and tines, (tire supplier variability can impact dimensions by 2%).

908 Compact Wheel Loader

STANDARD EQUIPMENT

POWER TRAIN

- Emissions compliant, two options*
 - U.S. EPA Tier 4 Final and EU Stage V
 - U.S. EPA Tier 3 and EU Stage IIIA
- Cat C2.8 engine
 - Diesel particulate filter (Fit for Life) or muffler*
 - Fuel, diesel, ultra low or low Sulphur*
 - Hydrostatic transmission, two speed, with inching function, “shift on the go”
 - Power train mode, hystat
- Air cleaner, two stage filter, with in cab audio/visual indicator on display
- Axles, heavy duty, frame mounted with outboard planetary reduction
- Closed circuit breather
- Coolant, extended life, -36° C (-33° F)
- Drive shaft, sealed for life, universal joints
- Engine, auto idle shutdown, hibernation mode
- Engine oil, ECO drain tap and hose
- Fuel pump, priming (manual)/water separator/drain

HYDRAULICS

- Caterpillar HYDO Advanced 10 hydraulic oil
- Coupler/pin on attachment ready
- Demand cooling fan, hydraulically driven
- Dead engine lower, lift valve, manual
- Electro-hydraulic, fully proportional controls
- Hydraulic pilot shut off switch, in cab
- Hystat displacement pump, infinitely variable
- Implement valve, pressure compensated
- Joystick, single lever, single auxiliary roller
- Multi-function lift and tilt with loader arm float
- Motor, single drive with dedicated implement and steering pumps

ELECTRICAL

- Alternator, 100 amp sealed
- Battery, heavy duty, 12V, 90Ah and 1,000 CCA
- Battery disconnect switch
- Cab mounted fuse panel
- Lights, rear stop and turn, LED
- Lights, roading, front halogen
- Service (Electronic Technician™)
- Product Link™

OPERATOR ENVIRONMENT

- ROPS/FOPS certified canopy/cab
 - 12V power outlets, interior/exterior
 - Pedals, raised, foot, brake/inching, accelerator
 - Lever, parking brake

*Dependent on regional regulations.

- Cup holders (2)
- CB radio clip, phone holder
- Door release, internal (left and right)
- Hook, large, coat and hard hat
- Floor mat, heavy duty, easy clean
- Mirrors, (2) external breakaway, (1) internal
- Operator station on isolation mounts
- Steering wheel, spinner knob, horn in center
- Seat belt, orange, retractable, 51 mm (2 in)
- Storage, personal (trays [3], seat pocket)
- Steering column, tilt adjusted
- Column mounted multi function control: lights, roading, wipers, self cancelling turn signals
- Quick coupler switch, in cab
- Display, analog and digital
 - Gauges (2), hydraulic oil, engine coolant
 - Digital with soft touch buttons – fuel level, speed range, speedometer, service hour meter, service/maintenance information, hydraulic and power train performance and aggressiveness settings, security passcode (multiple languages)
- Joystick, seat mounted, standard multifunction
 - FNR, auxiliary roller, speed range select, continuous flow, differential lock, horn
 - Arm rest, padded right, multiple position vertical height
- Seat, manual height adjustment, (cab) fabric with adjustable left arm rest, (canopy) vinyl
- Cab
 - Doors (2), fixed glass
 - Wipers, front and rear, full front coverage
 - Windshield, front single piece
 - Window, rear heated
 - Radio ready, speakers and wiring
 - Air vents, (4) screen, (7) directional
 - Heating, mechanical control unit
 - Sun visor, solid, front full width
 - Interior light (incandescent)

OTHER

- Fenders, front and rear
- Ground level easy access daily service points
- Loader arm safety brace
- Lockable main and side engine enclosures
- Lockable, fuel cap, HVAC filters, nose cone
- Machine lifting/tie down points
- Paint, Electro-Coat primer, gloss topcoat
- Recovery hitch with pin
- Scheduled Oil Sampling (S-O-SSM) ports, engine oil and hydraulic oil

OPTIONAL EQUIPMENT

POWER TRAIN

- Antifreeze, extended life coolant, -50° C (-58° F)
- Cold start – jacket water heater, bypass valve
- Creep and throttle lock function
- Fuel pump, priming, electric*
- 40 km/h (25 mph) hydrostatic transmission, 3-speed, “shift on the go”, secondary steering and boosted brakes
- Power train mode, utility (includes keypad)

ELECTRICAL

- Lighting packages, multiple; front, rear, engine bay (LED or HAL)
- Push to start
- Work tool wiring harness, (3) in cab switches

HYDRAULICS

- Auxiliary flow, single standard (3) valve, single high flow (3) valve, dual high flow (4) valve
- Caterpillar Bio HYDO Advanced hydraulic oil
- Connect under pressure and case drain
- Ride Control or load check valves*
- Reversing fan
- Quick disconnect auxiliary hydraulics

OPERATOR STATION

- Air Conditioning, automatic temperature control (ATC)
- Doors, sliding windows (left and right)
- Interior light, door activated
- Joystick, FNR, twin auxiliary roller, differential lock, horn
- Mirrors (2) electronically adjustable, heated external, plus lower parabolic mirror
- Phone holder, spring loaded
- Radio, FM or digital audio broadcast
- Seat belt options, multiple
- Seat packages; deluxe or premium
- Secondary display, front or rear view camera
- Soft touch keypad options, 8 or 16 button
- Storage, lockable box or lockable cooled box
- Sun visor, rear perforated
- USB ports (2), interior

OTHER

- Couplers, vertical (SSL), horizontal (HPL-V, HPL-A)
- Rotary sensors (snubbing, kickouts, parallel)
- High lift option

For more complete information on Cat products, dealer services, and industry solutions, visit us on the web at www.cat.com

© 2022 Caterpillar
All rights reserved

Materials and specifications are subject to change without notice. Featured machines in photos may include additional equipment. See your Cat dealer for available options.

CAT, CATERPILLAR, LET'S DO THE WORK, their respective logos, “Caterpillar Corporate Yellow,” the “Power Edge” and Cat “Modern Hex” trade dress as well as corporate and product identity used herein, are trademarks of Caterpillar and may not be used without permission.

AEHQ8412 (04-2022)
Build Number: 14A
(Global excluding Japan)

