



Locomotive Engine

3508C

920-1000 bkW

1234-1341 bhp

EU Stage IIIA

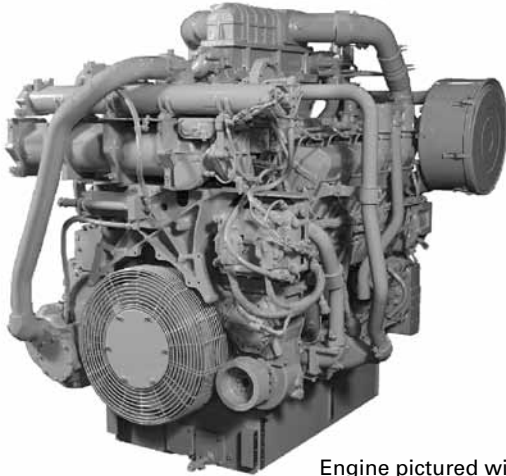

Engine pictured with optional equipment

CAT® ENGINE SPECIFICATIONS

8-Cylinder, Four-Stroke-Cycle Diesel

Bore	170 mm (6.7 in.)
Stroke	190 mm (7.5 in.)
Displacement	34.5 L (2105 in ³)
Aspiration	Turbocharged-Aftercooled
Rotation (from flywheel end)	Counterclockwise
Capacity for Liquids	
Cooling System	123 L (32 U.S. gal)
Lube Oil System (refill)	220 L (58 U.S. gal)
Weight, Net Dry (approx)	
Including flywheel	4582 kg (10,100 lb.)
Cold Start Capability	6° C (43° F)
Compression Ratio	14.7
Electronic Fuel Injection	Meets current EU Stage IIIA exhaust emissions levels

STANDARD ENGINE EQUIPMENT

Air Inlet System

2-stage aftercooler core, material: copper nickel
Two rear-mounted turbochargers

Control System

Fuel-cooled ADEM™ A3 electronic engine control, requires isolated 10 amps at 24-volts DC for operation

Cooling System

Thermostats and housing — full open temperature 92° C (198° F) for engine jacket water
Jacket water and separate circuit pumps — gear-driven, centrifugal
Separate Circuit Aftercooler (SCAC) cooling circuit contains a thermostat to maintain the aftercooler water temperature, requires customer-supplied cooling system to supply 47° C (117° F) water to meet exhaust emissions limits
Connections: jacket water — single inlet, dual outlet, hose type; separate circuit — flange type with companion flange

Exhaust System

Exhaust manifold, dry, gas tight, rear-facing single exhaust outlet

Flywheels and Flywheel Housings

Flywheel, SAE No. 00, 183 teeth
Flywheel housing, SAE No. 00
SAE standard rotation

Front Housing

Two-sided front housing

Fuel System

Fuel filters, cartridge type, RH service
Fuel transfer pump
Electronically controlled unit injectors

Lube System

Crankcase breathers, top mounted, 51 mm (2 in) OD outlet
Oil cooler
Oil filler, RH, with chained stopper
LH and RH dipstick
Oil filter, RH
Oil pump — gear type
Shallow oil pan

Power Take-Offs

Accessory drive — lower LH, used to drive SCAC pump

Protection System

ECU controlled warnings, derates, and shutdowns for coolant temperature, oil pressure, intake air restriction, crankcase pressure, and overspeed

General

Paint — Cat Yellow
Vibration damper and guard
Lifting eyes

Special Locomotive Equipment

Electrical interface
Remote junction box provides normal and emergency shutoff
Customer connection to ADEM control including: throttle; speed signal; General Alarm Relay (GAR), NC or NO contacts; Shut Down Notify Relay (SDNR), NC or NO contacts; Start Enable Relay (SER), NC or NO contacts; Cat Data Link; load feedback; torque limiting; remote emergency and normal shutdown switch connections; engine electrical power connections



Locomotive Engine

3508C

920-1000 bkW
1234-1341 bhp

OPTIONAL ENGINE EQUIPMENT

Air Inlet System

Air cleaners — single or dual element
Air inlet adapters for air cleaners

Control System

Customer Control Module (CCM) (shipped loose)
provides interface between engine control and
customer control
Throttle position signal conversion module (shipped
loose) — provides PWM signal to engine control
Instrument panel for remote mounting

Cooling System

Connections (shipped loose) - flexible hose and
mechanical connections for cooling water
Jacket water connections — flange connections for
cooling water inlet and outlet

Exhaust System

Exhaust fittings — flexible connections, flanges, and
elbows (shipped loose)
Exhaust port thermocouples
Heat shields

Flywheels and Flywheel Housings

Flywheel and housing SAE No. 0
Flywheel SAE No. 0

Fuel System

Fuel priming pumps (manual)
Flexible fuel lines (shipped loose)
Hard fuel return line includes flexible hose
connections
Primary fuel filter (shipped loose)
Water/fuel separator (shipped loose)
Fuel filter with left-side service
Fuel cooler (shipped loose)

Lube System

Oil pan accessories: oil pan capacities, oil pan drain
cover, filler, sampling and drain valve
Oil filter with left-side service
Fumes disposal (shipped loose) — provides hard
fumes disposal tube and flexible hose to route
fumes out of the engine compartment
Lubricating oil

Mounting System

Rails (ledge-type)

Power Take-Offs

Front accessory drives
Auxiliary drive shafts and pulleys
Front stub shafts and pulleys

Protection System

Explosion relief valve
Discrete I/O Module — provides 12 digital inputs
and 8 FORM C relay outputs, configurable by ET
ECU also provides diagnostic capability

Starting System

Electric starting motors (dual)
Electric starting motor magnetic switch enclosure
Air starter



Locomotive Engine

3508C

920-1000 bkW
1234-1341 bhp

PERFORMANCE CURVES AND DATA

Turbocharged-Aftercooled — 1800 rpm

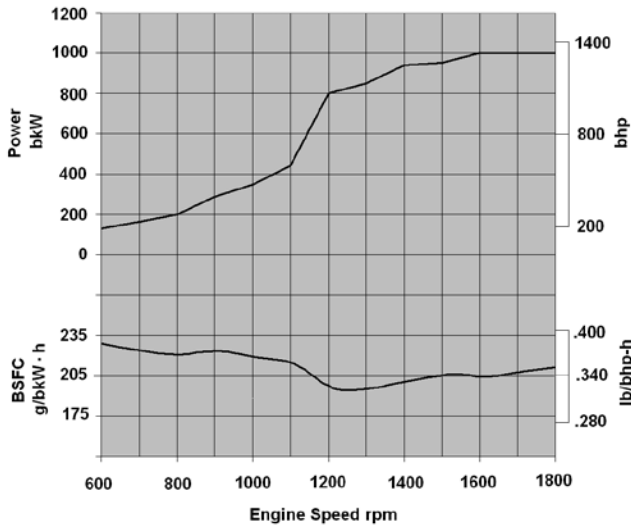

DM8711

Rated bkW (bhp) flywheel	1000 (1341)
Full Load — rpm	1800
Low Idle — rpm	600
Operating Range — rpm	600-1800
Altitude Capability — m (ft)	
max operating altitude	1120 (3675)
Fuel Consumption — L/hr (gal/hr)	
Idle (600 rpm)	4.5 (1.2)
Full Load (1800 rpm)	253.2 (66.9)
BSFC — g/bkW-hr (lb/bhp-hr)	
Full Load (1800 rpm)	212.4 (.349)

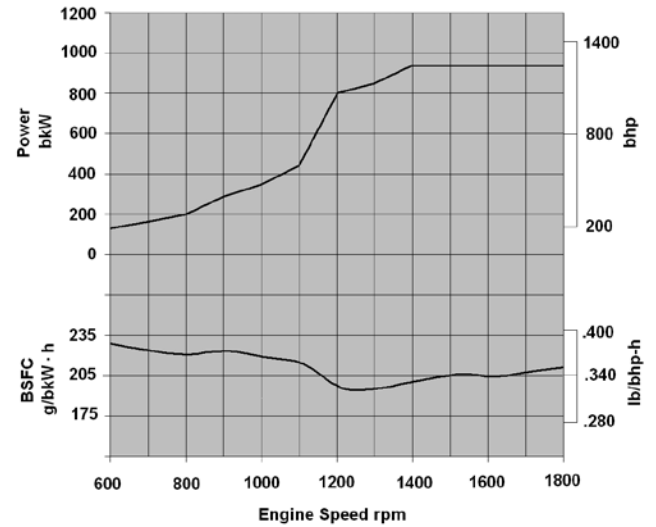

DM8758

Rated bkW (bhp) flywheel	920 (1234)
Full Load — rpm	1800
Low Idle — rpm	600
Operating Range — rpm	600-1800
Altitude Capability — m (ft)	
max operating altitude	1600 (5250)
Fuel Consumption — L/hr (gal/hr)	
Idle (600 rpm)	4.5 (1.2)
Full Load (1800 rpm)	231.7 (61.2)
BSFC — g/bkW-hr (lb/bhp-hr)	
Full Load (1800 rpm)	211.3 (.347)



Locomotive Engine

3508C

920-1000 kW
1234-1341 bhp

ENGINE DIMENSIONS

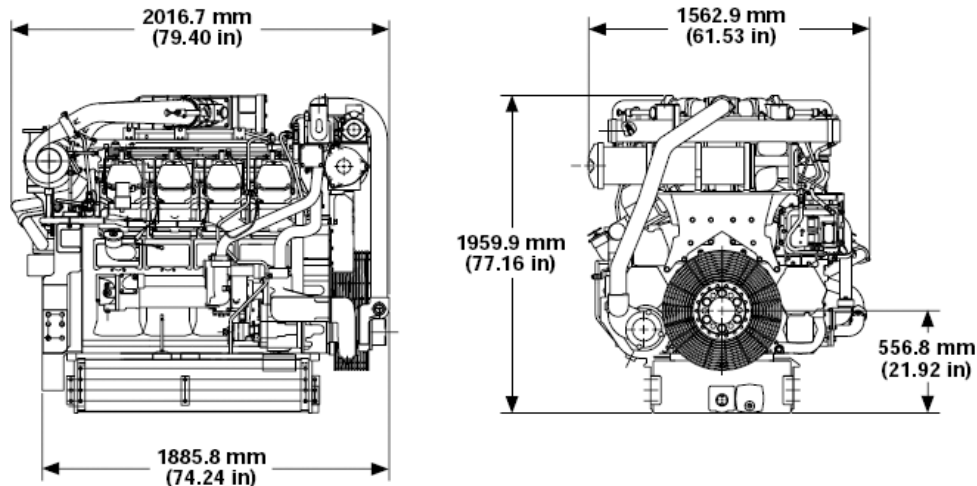

RATINGS DEFINITIONS AND CONDITIONS

Performance obtained and corrected in accordance with ISO3046/2 standard atmospheric conditions of 99 kPa (29.31 in Hg) and 25° C (77° F). These values correspond to the standard atmospheric pressure and temperature as shown on SAE J1995.

Performance and fuel consumption are based on 35 API 15° C (60° F) gravity fuel having an LHV of 42 780 kJ/kg (18,390 Btu/lb) when used at 29° C (85° F) where the density is 839.9 g/liter (7.001 lb/U.S. gal). Tolerance is +/- 3%.

Engine equipped with fuel, lube oil, and water pumps.

Materials and specifications are subject to change without notice. The International System of Units (SI) is used in this publication. CAT, CATERPILLAR, their respective logos, ADEM, "Caterpillar Yellow" and the "Power Edge" trade dress, as well as corporate and product identity used herein, are trademarks of Caterpillar and may not be used without permission.