

**EU Locomotive Stage V  
839-895 bkW/1125-1200 bhp @ 1800 rpm**



Image shown may not reflect actual configuration

## Specifications

<b>Cat® C32 Locomotive Engine</b>	<b>Metric</b>	<b>Imperial (English)</b>
Configuration	V-12, 4-Stroke-Cycle Diesel	
Bore	145 mm	5.71 in
Stroke	162 mm	6.38 in
Displacement	32.1 L	1958.9 in <sup>3</sup>
Aspiration	Dual Turbochargers, Air-to-Air Aftercooled	
Compression Ratio	15.0:1	
Rotation (from flywheel end)	Counterclockwise	
Capacity for Liquids – Cooling System Lube Oil System (refill)	67.9 L 68 L	71.7 U.S. qts 71.9 U.S. qts
Weight, Net Dry (approx.)	2946 kg	6495 lb
Flywheel and Flywheel Housing	SAE No. 0 or SAE No. 1	

## Features

### Emissions

Designed to meet EU Stage V locomotive emission standards

On-engine NOx reduction system with optimized piston, ring, liner, and fuel system configuration to reduce NOx while minimizing in-cylinder sooting

Aftertreatment features diesel oxidation catalyst

### Engine Design

Proven reliability and durability of engine and aftertreatment

Broad operating speed range

High power density

PTO drive options provide flexible access to auxiliary power for pumps and other needs

### Low Total Cost of Ownership

Optimized fuel consumption

Maintenance-free aftertreatment

### Control System

Electronic control system, over-foam wiring harness, automatic altitude compensation, power compensated for fuel temperature, configurable software features, engine monitoring system, SAE J1939 broadcast. ADEM A4 has improved: user interface, display system, shutdown controls, and system diagnostics.

### Testing

Every engine is full-load tested to ensure proper engine performance.

### Product Support Offered Through Global Cat Dealer Network

More than 2,200 dealer outlets

- Caterpillar factory-trained dealer technicians service every aspect of your locomotive engine
- Caterpillar parts and labor warranty
- Preventive maintenance agreements available for repair-before-failure options

S•O•S<sup>SM</sup> program matches your oil and coolant samples against Caterpillar set standards to determine:

- Internal engine component condition
- Presence of unwanted fluids
- Presence of combustion by-products
- Site-specific oil change interval

### Over 80 Years of Engine Manufacturing Experience

Ownership of these manufacturing processes enables Caterpillar to produce high-quality, dependable products.

- Cast engine blocks, heads, cylinder liners, and flywheel housings
- Machine critical components
- Assemble complete engine

## Standard Equipment

### Aftertreatment

Two DOC canisters remote- or engine-mounted

### Air Inlet System

Twin side-mounted turbochargers  
Air-to-air aftercooled

### Control System

Automatic altitude compensation  
Power compensation for fuel temperature  
Electronic diagnostics and fault logging  
Engine monitoring and protection system  
(speeds, temperature, pressure)  
J1939 Broadcast (diagnostic, engine  
status, and control)  
ADEM A4 electronic control

### Cooling System

Thermostats and housing  
Jacket water pump, gear driven,  
centrifugal, RH

### Exhaust System

Exhaust dry manifold  
Rear-facing or forward-facing exhaust

### Fuel System

Mechanical Electronic Unit Injection (MEUI™)  
system  
Primary, secondary, and tertiary fuel filter  
Electronic fuel priming pump — integrated  
with primary fuel filter base  
Fuel transfer pump

### Lube System

Oil cooler — RH  
Oil filler — RH, LH, or Dual  
Oil level gauge — RH, LH, or Dual

### Power Take-off

SAE A, B, C, & E drives available  
Engine power can also be taken from front of the  
engine on some applications

## Optional Equipment

Air inlet adapters  
Battery charger — 10 amp  
Charging alternator — 24V  
Flywheel housing — SAE No. 1 and heavy-duty  
SAE No. 0  
Oil pan — high capacity  
Starting motor — dual 24V

Jacket water heater — 120V and 240V  
Air inlet shutoff valve  
Freon compressor  
Digital tachometer  
J1939 messenger display  
Instrument gauge panel — 24V  
Air compressor — belt driven

## Engine Dimensions

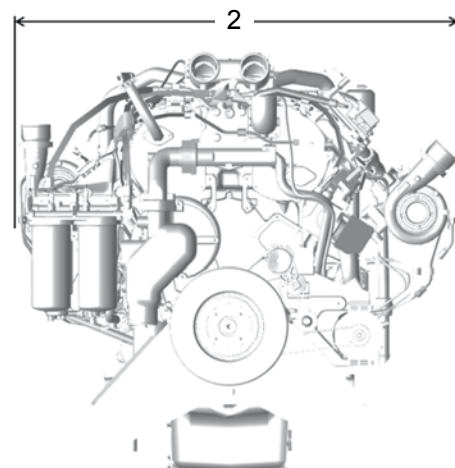
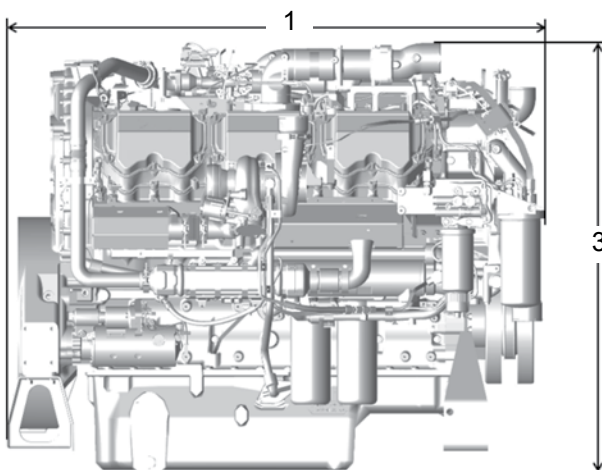

(1) Length — 1819 mm (71.6 in)

(2) Width — 1527 mm (60 in)

(3) Height — 1442 mm (56.7 in)

**Note:** Final dimensions dependent on selected options

## Performance Data

Twin Turbocharged-Aftercooled — 1800 rpm

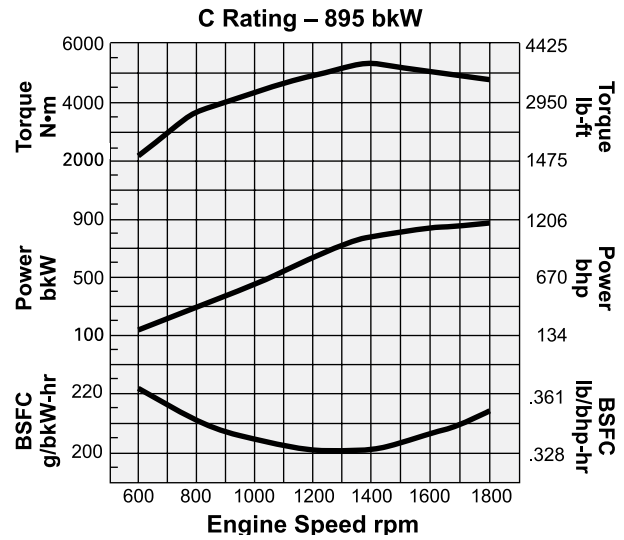
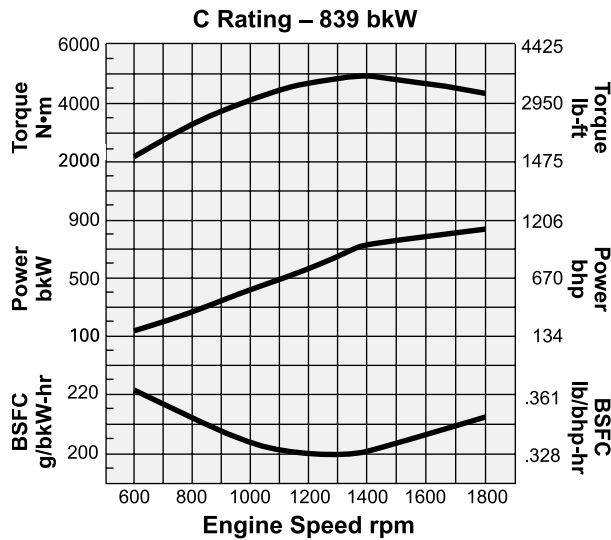

Rating	Peak Power			Peak Torque		
	Speed rpm	Peak Power kW	Peak Power bhp	Speed rpm	Peak Power kW	Peak Power bhp
C	1800	839	1125	1350	5052	3726
C	1800	895	1200	1350	5367	3959

## Ratings Definitions and Conditions

**C Rating (Intermittent)** service where maximum power and/or speed are cyclic (time at full load not to exceed 50%).

**Engine Performance Diesel Engines — 7 liter and higher** are based on SAE J1995, inlet air standard conditions of 99 kPa (29.31 in Hg) dry barometer and 25°C (77°F) temperature. Performance measured using a standard fuel with fuel gravity of 35° API having a lower heating value of 42 780 kJ/kg (18,390 btu/lb) when used at 29°C (84.2°F) with a density of 838.9 g/L.

## Clean Emissions Module Aftertreatment Engine-mounted Configuration

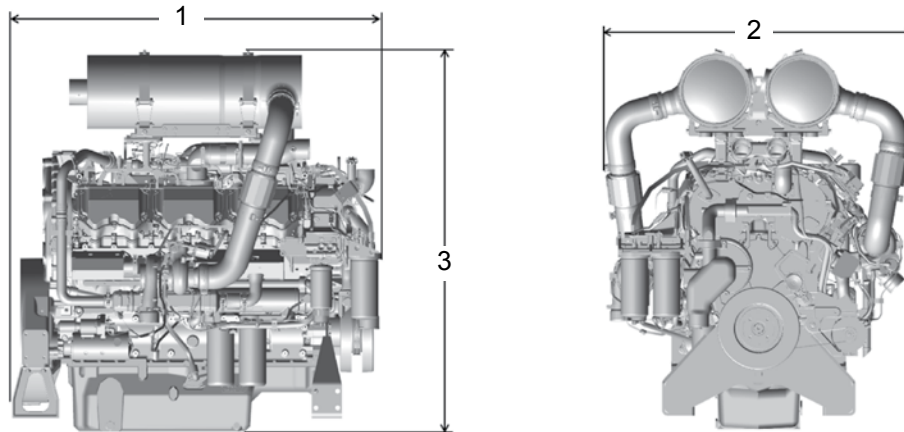

(1) Length — 1819 mm (71.6 in)      (2) Width — 1528 mm (60.1 in)      (3) Height — 1886 mm (74.2 in)

## Clean Emissions Module Aftertreatment Remote-mounted Configuration

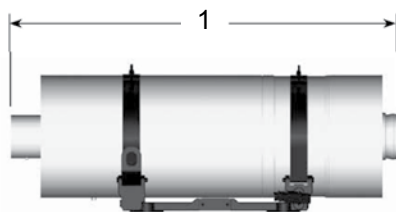

Images shown may not reflect actual configuration

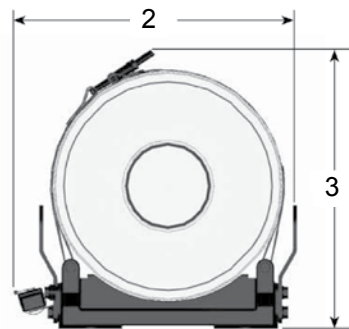

### AFTERTREATMENT DIMENSIONS\*

#### Approximate Size and Weight

- (1) Length — 1120 mm (44 in)
  - (2) Width — 400 mm (15.7 in)
  - (3) Height — 440 mm (17.3 in)
- Weight — 66 kg (145 lb)

\*Dimensions and image are for individual canister. Two canisters are required. They can be shipped loose for customizable mounting options.

Each canister features a single diesel oxidation catalyst. Two canisters required to meet emission standards.

### Aftertreatment Features

**Factory-installed engine-mounted aftertreatment.** Forward exhaust only applications.

**Remote installation options** provide OEM flexibility for many applications. Rear or forward exhaust applications.

## Standard Emissions Control Equipment

**DOC:** Diesel Oxidation Catalyst

**NRS:** NO<sub>x</sub> Reduction System

Materials and specifications are subject to change without notice. CAT, CATERPILLAR, LET'S DO THE WORK, their respective logos, ADEM, S•O•S, MEUI, "Caterpillar Yellow", the "Power Edge" and Cat "Modern Hex" trade dress as well as corporate and product identity used herein, are trademarks of Caterpillar and may not be used without permission.